

4 Gains into the wheel Radial 12,5X25 (300Amp)

EARTHING RETURN CURRENT UNITS (ERCU)

EARTHING CONTACTS FOR METRO AND TRAM



The flow of electric current through the axle box roller bearing of railway vehicles is one major problem for the safety and reliability of rolling stock.

The electrification of networks, the increase of power installed on board vehicles and higher speeds lead to an increase of risks of bearings damaged by electric current flow. As a result, the use of Earth Return Current Units, already indispensable on electric locomotives, is being extended to other vehicles by the large European railway companies.

Since 50 years, Mersen devices by virtue of their effectiveness (low contact resistance, permanence of contact), are very well suited for the protection of such bearings.

On all the vehicles of a train, the currents that can flow through the axle box roller bearing have various origins and their magnitude varies from the first to the last vehicles. The origins are:

- The electric locomotive or power car: Traction current in the return current path and current supplied in the return path from trailer vehicles. This latter origin also applies to diesel electric traction.

- The trailer vehicles equipped with generators supplying power to several trailers of a train where the return path is formed by earthing of the vehicles.

- The track: return current of trains running on the same track; signalling currents; stray currents emanating from industrial trackside installations.

In the 3 cases above, train and track are parallel conductors.

- Accidental: faulty insulation on one or more pieces of electrical equipment on board any of the vehicles; overhead line falling onto the train.

The flow of current through roller bearings while the vehicles are

FEATURES & BENEFITS

- Protected against dust penetration, water splash and shock
- Permanence of contact
- Very Low maintenance cost
- Fast and easy brush replacement
- Low cost and simple fixing on the bogie
- The Radial contact brushes provide an effective shunt around the bearings.
- There is a possibility to supply a complete adaptation including the guard, slip ring, etc...

APPLICATIONS

- Earth Return Current Unit for Low Floor Tramways



4 Gains into the wheel Radial 12,5X25 (300Amp)

stationary or running, produces damages characterized by craters or scoring (washboarding) respectively and whose development is dangerous. This result in substantial overheating leading to the destruction of the roller bearing or seizure of the axles.

To avoid such damages, it is necessary to use devices shunting the greatest part of the current through the axles and wheels without flowing through the roller bearings.

Some references :

Railway :

Alstom Citadis Bordeaux, Lyon, Montpellier, Nice, Strasbourg, etc...

TECHNICAL DATA

300 Amp 4G 12,5x25

Mounting	Radial
Rated current	300 A
Number of brushes	4
Cross section of the brushes	12,5 x 25 mm
Short time withstand current 100ms	7 kA
Short time peak withstand current	19 kA
Resistivity	5 mΩm
Constant brush pressure	34 kPa
Material of body	Stainless cupro Aluminium, connection tinned
Material of spring and screws	stainless steel
Material of insulating ring	Polyester glass fiber

DIMENSIONS

Earth Return Current Unit - 4 brushes 12,5 x 25 - into the wheel (dwg 114668)

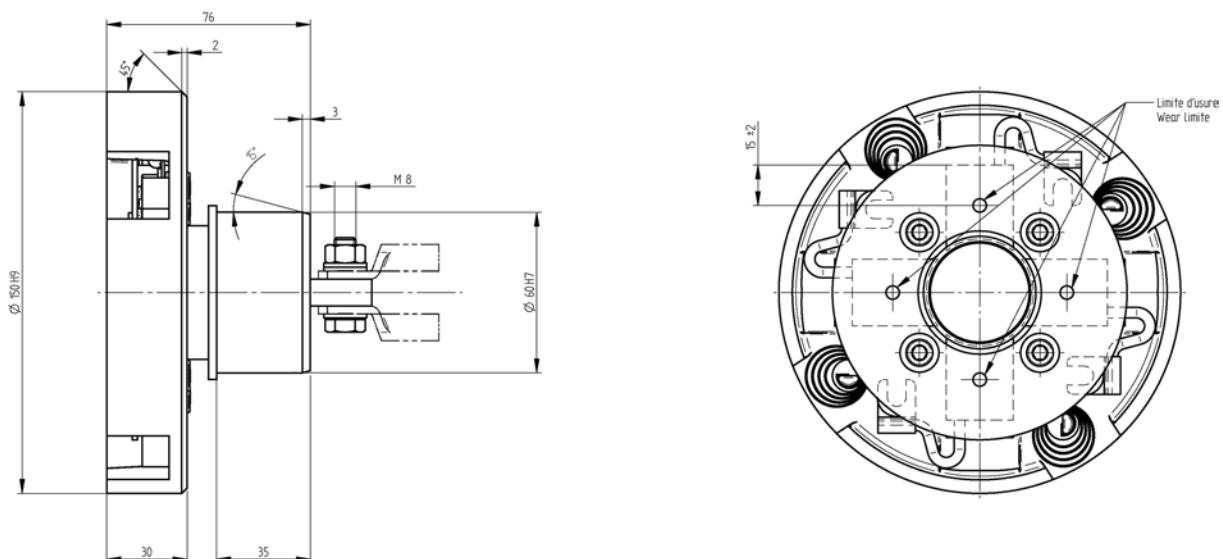

4 Gains into the wheel Radial 12,5X25 (300Amp)

FUNCTIONS

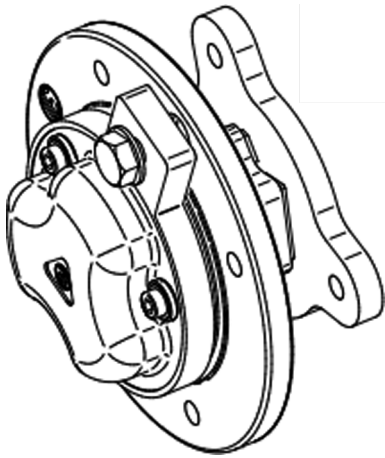

Operations

In the patented Earth Return Current Unit the contact is made to the axle end by means of 2 independent brushes guided in 2 boxes of rectangular section in the radial direction of the axle. Two independent pressure systems of the close coiled roller spring type without inertia, apply a constant pressure to each of the 2 brushes.

The Earth Return Current unit is fitted to the axle by means of an adaptation part which replaces the axle box end cover, and is therefore easily accessible. For the inspection purposes, it is a simple matter of undoing 3 screws removing the cover/spring assembly for access to the brushes. An insulating support positioned between the Earth Return Current Unit and part ensures the effective shunting of the roller bearing by the unit.

The connection lug for the electrical connection is an integral part of the unit.

The rotating contact face is a disc fitted to the axle end and possibly protected against lubricants emanating from the axle box bearing by a guard.

Due to the simplicity of the device and the very slow rate of brush wear (about 1 to 3mm per 100'000 km or 190'000 miles after patina creation), maintenance required is virtually zero. With the appropriate brush grade the formation of the skin on the surface of the contact disc can be observed and no evidence of hammering nor bevelling appears on the brush contact faces. The brushes are generally a metal graphite mixture grade manufactured by Mersen.

Contact disc - Slip disc

Mersen can study, design and supply the slip disc adapted to your axel end



Brushes

For the maintenance, the replacement brushes designed and dedicated to your Ground Brush can be provided by Mersen



4 Gains into the wheel Radial 12,5X25 (300Amp)

FUNCTIONS



Connexion cables + Braided cable

Connexion cables or braided cables are studied for your application.

Mersen can supply and guarantee them.

They are delivered with the possibility to customized the total length plus the adapted hardware for bolted connection.



Training and technical support

All around the world, Mersen technical team can help you for technical support and can offer you customized training sessions for your Maintenance team.



LCC; RAMS; Type tests

Mersen teams can supply Life Cycle Costs "LCC" and Reliability Availability Maintainability Safety "RAMS" and Faillure Mode and Effect Analysis "FMEA" studies. They can operate Qualification type tests.

ACCESSORIES



12,5 X 25 mm Brush

Brushes

Catalog number	Package	Weight
Brushes 12,5 X 25	24	15 g



S/E FROTTEUR RDC Citadis

Slip disc

Catalog number	Item number	Package	Weight
S/E FROTTEUR RDC CITADIS	G114937	1 piece	1.04 kg

4 Gains into the wheel Radial 12,5X25 (300Amp)

ACCESSORIES



Silohm resistances

Silohm resistances

Catalog number	Item number	Package	Weight
RD6 R0,04/10 EPAIS.11	N1048421A	-	40 g
RD6 R0,010/10 EPAIS.11	P1048422A	-	40 g
RD6 R0,04/20 EPAIS10	X202443A	-	40 g
RD6 R0,05/20 EPAIS.11	Y202444A	-	40 g
PAPYEX WASHER EP:0,4 48MM	Z202445A	-	5 g
STAINLESS STEEL WASHER 17X50	A154008	-	50 g
INSULATING BUSHING 16X19	W1048428	10 pieces	25 g
INSULATING BUSHING 30X18	G154014	-	25 g
STAINLESS STEEL WASHER DIAM 50	X1048429	-	60 g
COVER 8x53	Y1048430	-	10 g